

## AV-400

### Rectangular Rapid Flashing Beacon (RRFB)

Purpose built from the ground up, the AV-400 has raised the bar for RRFBs.

Every aspect of the design from the controller to the mounting brackets incorporate features to minimize installation time and expense.

High efficiency LED modules and an ultra-low power purpose-built controller deliver dependable year-after-year operation.

### Performance

- ✓ High intensity light output exceeds MUTCD requirements by up to five times
- ✓ Rated operating capacity exceeding 300 activations per day

### Solar Engine Design

- ✓ Compact, low profile design ideal for aesthetically significant streetscapes
- ✓ Solar engine housing with hinged solar panel mount, battery compartment, controller, and integrated pole mount
- ✓ Thermally isolated solar panel reduces battery ambient temperature to maximize battery life
- ✓ Install-ready universal pole mount system
- ✓ Designed for quick and simple installation; complete system installs on standard sign poles in under 15 mins



### Lightbar Design

- ✓ Three-point pivoting mounting bracket provides superior holding strength
- ✓ Easily bolts or bands to any pole size
- ✓ Powder coated black or yellow front panel
- ✓ Innovative single circuit system for RRFB module and pedestrian confirmation\*

### Wireless Operation

- ✓ Automatic synchronized activation of multiple systems, no configuration required
- ✓ Field adjustable channel selection for independent operation of multiple crosswalks in proximity

# AV-400 RRFB Specifications

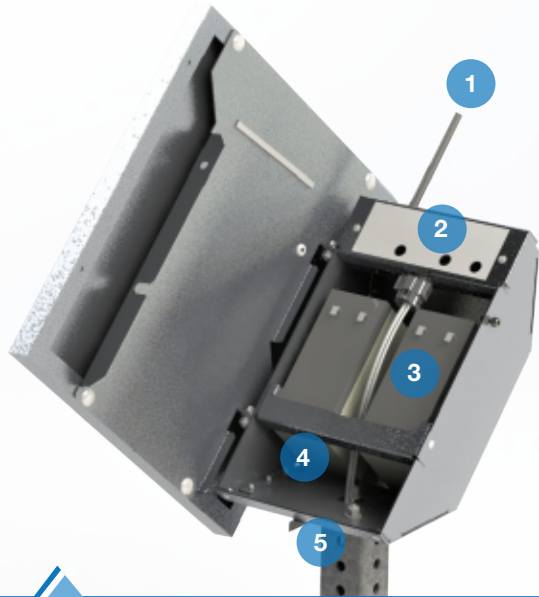

1. Configuration-free wireless connection between units
2. Adjustable switches for flash duration, channel, night intensity
3. Easy-install batteries with quick connectors
4. Pre-wired, two cable system for lightbars
5. Factory-installed universal pole mount for rapid installation

## Operational

- Dual (back-to-back) or single lightbar configuration
- MUTCD compliant
- WW + S (wig-wag plus simultaneous) flash pattern
- Exceeds SAE J595 Class 1 specifications
- Automatic night dimming
- Meets SAE J578 chromaticity specifications
- Field adjustable flash duration, channel, night intensity
- Capacity: 300, 20 second activations per day
- 30 day system autonomy

## System

- 20W high efficiency monocrystalline solar panel
- 45° tilt angle, 360° rotation
- 12V 14Ah battery capacity, AGM sealed lead acid
- Ultra low-power controller with integrated processor, Maximum Power Point Tracking (MPPT) charger wireless module, and field configuration
- 2.4 GHz wireless mesh network, 10 channel, 1000' range
- Synchronized wireless activation under 150ms
- Weight (including mount and batteries): 19.1lbs

## Activation

- Compatible with Polara BDSP-014 BullDog III and Campbell 4 EVR MOAB solid state push buttons with LED and audible tones

1. 3-point pivoting mounting bracket with superior holding strength
2. Bolt or band to all pole types
3. Front-access with quick-connect wire terminals
4. Integrated pedestrian confirmation lights (both ends)\*

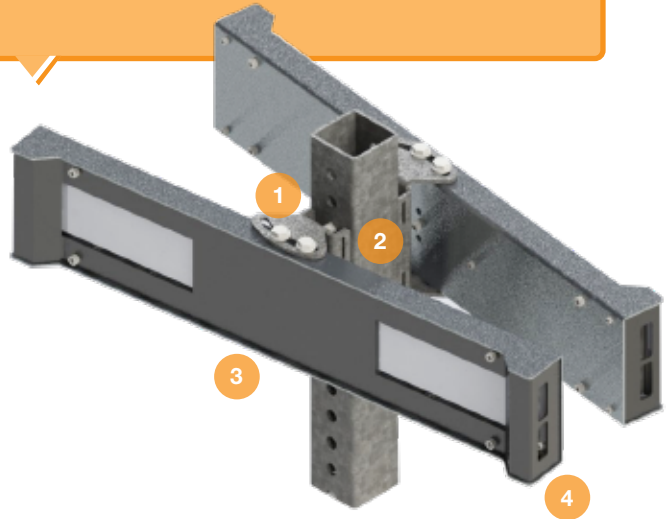

## Installation

- Pre-wired post-top solar engine assembly
- Hinged solar panel for easy front access to install batteries
- Quick connect battery connections
- Simple two wire run; one wire to the lightbars and one wire to the push button
- Quick connect wire terminal at lightbar

## Pole Mount

- Universal pole mount for solar engine and lightbar, compatible with 2", 2 1/4", 2 1/2" square telespar, 2 3/8" - 4 1/2" round pole
- Side of pole mount option

## Environmental

- System operating temperature: -40 to 165° F (-40 to 74° C)
- Battery operating temperature: -40 to 140° F (-40 to 60° C)
- Compliant to NEMA TS 2, Sections 2.2.7, 2.2.8, and 2.2.9 for temperature/humidity, vibration, and shock

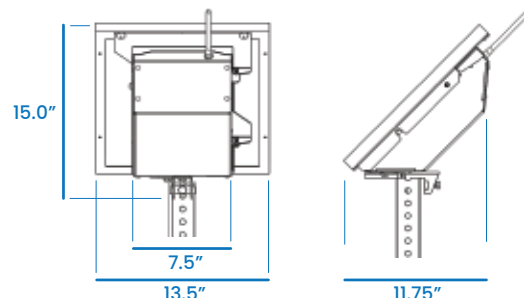

5 year limited warranty. \*Patent Pending. Specifications subject to change. Rev 1.1